



Display module for modular entry panel

FA01474-EN

CE

FC

EAC

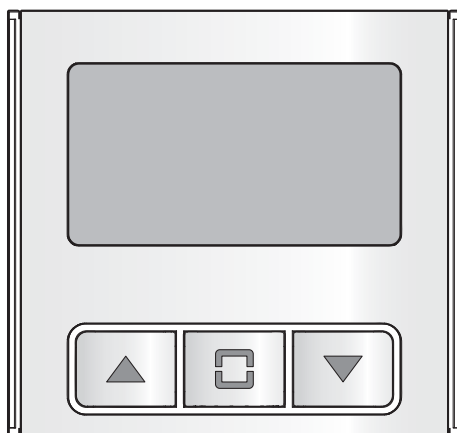

MTMDY

INSTALLATION AND PROGRAMMING MANUAL

EN English

General precautions

- Read the instructions carefully before beginning the installation and carry out the actions as specified by the manufacturer.
- The installation, programming, commissioning and maintenance of the product must only be carried out by qualified technicians, properly trained in compliance with the regulations in force, including health and safety measures and the disposal of packaging.
- Before carrying out any cleaning or maintenance operation, disconnect the device from the power supply.
- The equipment must be destined solely for the use for which it was expressly designed.
- The manufacturer declines all liability for any damage as a result of improper, incorrect or unreasonable use.
- This device complies with Part 15 of the FCC Rules. Operation is subject to the following two conditions:
 - 1 - This device may not cause harmful interference.
 - 2 - This device must accept any interference received, including interference that may cause undesired operation.

DESCRIPTION

Display module connected and powered via BUS.

⚠ Module assembly or removal must take place while the entry panel is not powered.

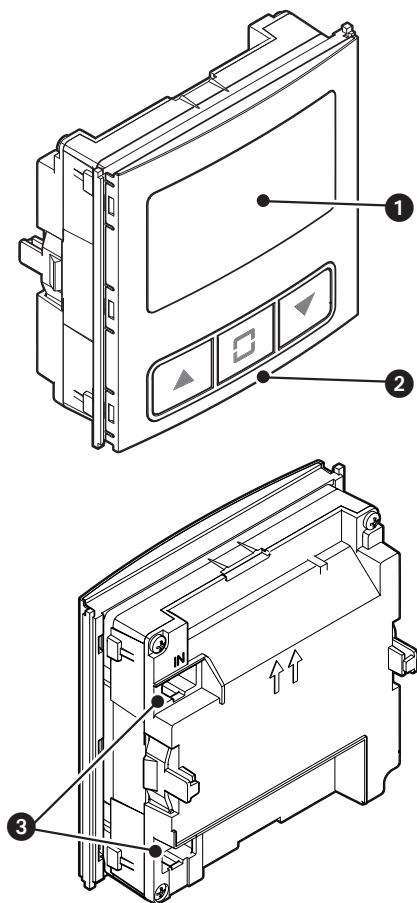

- 1 Display
- 2 Navigation buttons
- 3 Outlets for connection to other modules

Technical data

Type	MTMDY
Power supply (V DC)	10.7 to 18
MAX current draw (mA)	250
MIN current draw (mA)	55
Storage temperature (°C)	-25 to +70
Operating temperature (°C)	-25 to +55
Protection rating (IP)	54

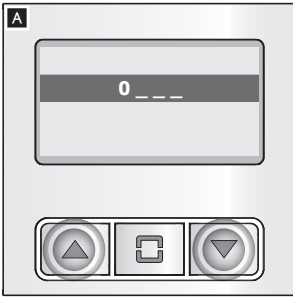

Accessing configuration mode

Press and hold the ▲▼ buttons at the same time until the password entry screen shown in figure **A** appears (default password 1234).

Use the ▲▼ buttons to enter the first of the four numbers that make up your password. Press to confirm and move on to the next number.

Once you have entered the correct password, you can access the dedicated module configuration section **B**.

Use the ▲▼ buttons to scroll through the various parameters to configure. Press to access the configuration options.

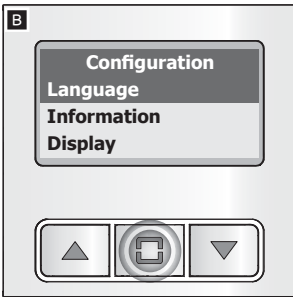

[Language] **C**

Scroll through the list of available languages **C** using the ▲▼ buttons. Press to choose the one you require and go back to the previous menu.

Select ← and press to go back to the previous menu without changing the existing programming.

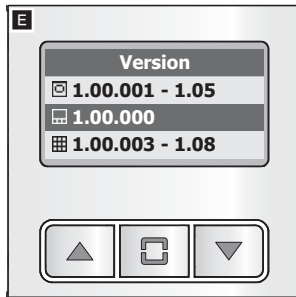
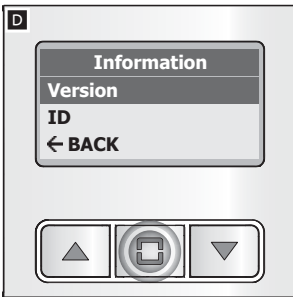

[Information] **D**

The menu provides technical information regarding the display module and the other modules installed on the entry panel.

[Version] **E**

The ▲▼ buttons allow you to scroll through the list and view the firmware version of the modules installed on the entry panel.

Key to symbols

audio or audio/video	pushbutton panel
display	keypad
RFID	info

Select ← and press to go back to the previous menu.

[ID] **F**

The information contained in this menu refers to the audio or audio/video module installed on the entry panel.

SN: identification code (also found on the back of the module),

IP: IP address of the module and subnet mask (information only found on IP modules).

Select ← and press to go back to the previous menu.

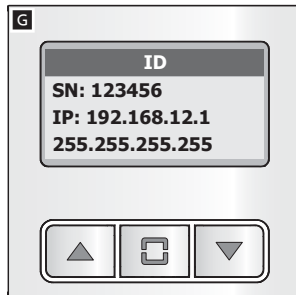
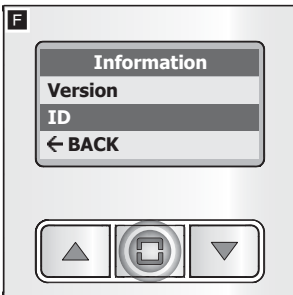

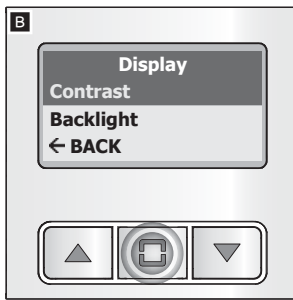
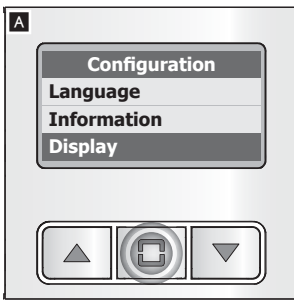

From the main menu **A**, use **▲▼**, to select [Display] and press **□** to access the configuration options.

[Display] **B**

The menu allows you to adjust all the parameters relating to display lighting.

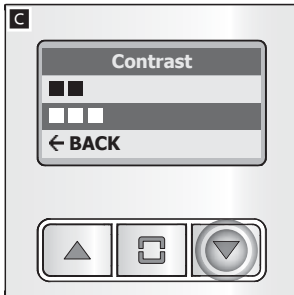

[Contrast] **C**

The **▲▼** buttons allow you to scroll and simultaneously view the available contrast levels. Press **□** to choose the required level and go back to the previous menu. Select **←** and press **□** to go back to the previous menu without changing the existing programming.



[Backlight] **D**

[Colour] **E**

The **▲▼** buttons allow you to choose the colour of the display backlight.

Press **□** to confirm your choice and go back to the previous menu.

Select **←** and press **□** to go back to the previous menu without changing the existing programming.

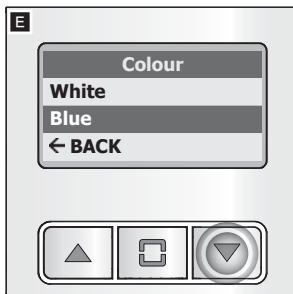

[Brightness] **F**

The **▲▼** buttons allow you to scroll and simultaneously view the available brightness levels.

Press **□** to choose the required level and go back to the previous menu.

Select **←** and press **□** to go back to the previous menu without changing the existing programming.



[Standby] G

The ▲▼ buttons allow you to determine the behaviour of the display module after 30 seconds of inactivity.

OFF = The backlight is always on.

ON = The screen dims the display until a button is pressed.

If you choose to activate the [Standby] function (ON), pressing allows you to access the window for adjusting brightness in Standby mode **H**.



The ▲▼ buttons allow you to scroll and simultaneously view the available brightness levels for Standby mode.

Press to confirm your choice and go back to the previous menu.

Select ← and press to go back to the previous menu without changing the existing programming.

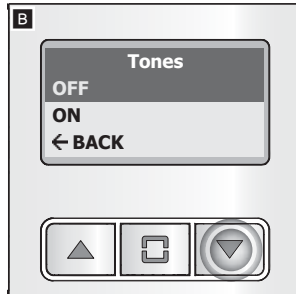
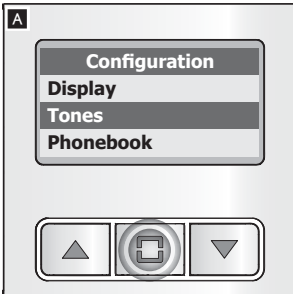

From the main menu **A**, use ▲▼, to select [Tones] and press to access the configuration options.

[Tones] B

The ▲▼ buttons are used to activate/deactivate tones.

Press to confirm your choice and go back to the previous menu.

Select ← and press to go back to the previous menu without changing the existing programming.

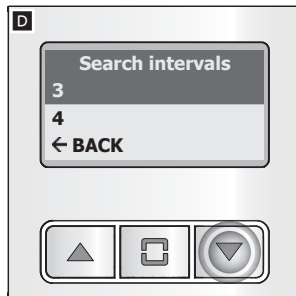
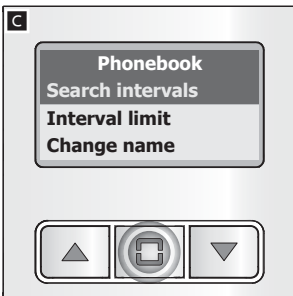

[Phonebook] C

The menu allows you to configure the way in which the names in the phonebook are displayed in order to facilitate the user in searching for the required name.

It also allows the names in the directory to be locally modified

[Search intervals] D

The ▲▼ buttons allow you to choose into how many parts to divide the phonebook.

Press to confirm your choice and go back to the previous menu.

Select ← and press to go back to the previous menu without changing the existing programming.

N.B. If you choose option [1], the phonebook name list will not be divided up in any way.

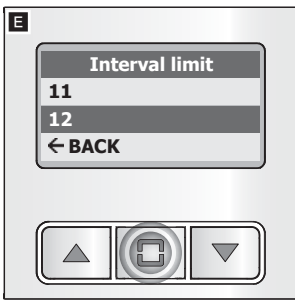

[Interval limit] E

The ▲▼ buttons allow you to choose the maximum number of permissible names for each search range. Below this limit, the phonebook is not divided up any further.

Press to confirm your choice and go back to the previous menu.

Select ← and press to go back to the previous menu without changing the existing programming.

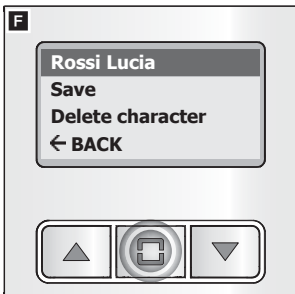

[Edit name]

The edit name menu initially displays as a straight list of names of users.

Use the ▲ and ▼ buttons to choose the name to be edited.

Press button to confirm your choice and access the edit menu.

Select ← at the end of the list of names and press button to go back to the previous menu without changing the existing programming.

Edit name menu F

Once you have selected the name to be edited, the first line displays the name being edited.

Note: to change the selected name, you need an MTMKB keypad G.

Press the button corresponding to the desired letter until it is displayed on the first line.

Repeat for all of the following characters.

Use the ▲ and ▼ buttons to choose the operation to be performed.

Press button to perform the selected operation (**Save** to save the new name, **Delete character** to delete the last character entered).

Select ← and press button to go back to the previous menu without changing the existing programming.

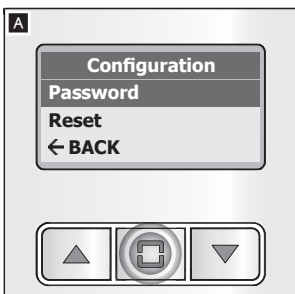

From the main menu A, use ▲▼, to select [Password] and press to change the password.

[Password] B

At any point in the process you can select ← and press to return to the previous menu without changing the existing password.

Press to change the current password and continue.

Use the ▲▼ buttons to enter the first of the

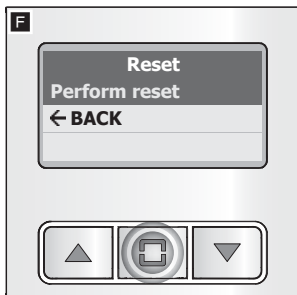

four numbers that make up the old password. Press to confirm and move on to the next number.

Once you have entered all the numbers in the old password , enter the new password as required .

From the main menu , use , to select [Reset] and press .

[Reset]

Select and press to go back to the previous menu without resetting.

Press to reset and return the entry panel to its factory settings.

The product complies with the applicable reference directives.

Dismantling and disposal. Dispose of the packaging and the device properly at the end of its life cycle, according to the regulations in force in the country where the product is used. The recyclable components bear the symbol and code for the material.

THE DATA AND INFORMATION PROVIDED IN THIS MANUAL ARE SUBJECT TO CHANGE AT ANY TIME WITHOUT PRIOR NOTICE.

MEASUREMENTS, UNLESS OTHERWISE INDICATED, ARE IN MILLIMETRES.

CAME 
BPT

CAME.COM

CAME S.P.A.

Via Martiri Della Libertà, 15
31030 Dosson di Casier - Treviso - Italy
tel. (+39) 0422 4940 - fax. (+39) 0422 4941